

AUTO ELECTRIC GUN

CM.031 (031B)

SEMI&FULL AUTOMATIC GNU

Users restricted to
18 years of age or older
使用年齡對象18歲以上



CM.031



CM.031B

Always read through this manual before operation.

在操作之前必需读熟这些说明书



警告 WARNING



18岁以上年龄才能使用
Only for 18 years
of age or older

18岁以上年龄才能利用这支汽枪比赛使用
Operation of this air gun for competition use is restricted to users of 18 years of age or older.



注意受损伤
Injury caution

因为BB 弹能达到50-60米范围, 不小心的射击将可能导致眼睛受损伤或其它伤害。
Since plastic BB bullets reach 50 to 60 meters, careless shooting may cause eye damage or other injuries.



注意熟读警告指示手册
Careful reading of
Handling cautions
and
Instruction manual

在操作之前要细心读熟警告手册和指示手册操作汽枪时必须认识好警告指示
Always read through this HANDLING CAUTION AND INSTRUCTION MANUAL carefully before operation.
Operate the air gun with full recognition of warnings and cautions.



WARNING

警告

HANDLING CAUTIONS AND INSTRUCTION MANUAL

操作汽槍之前請仔細閱讀操作手冊

This sport gun is developed for enjoying sport shooting through correct sport shooting operation. You can experience unique feel of the air gun, which is a most suitable sport goods to improve your shooting sense, if you recognize its features and operational warnings. As the air gun has the capacity to shoot BB bullets by 50to60 meters, careless shooting and wrong operation are dangerous, causing eye damage or other injury. Make sure to read through warnings stipulated below and observe rules and manners for pleasant sport shooting.

該款運動槍通過正確的運動射擊操作，為喜歡射擊運動的人而設計開發的。如果你清楚了解了該氣槍的特征和操作注意事項，你就能體驗到獨一無二的感受。該氣槍是你提高射擊能力最合適的運動器材。由于該氣槍能夠將BB彈射到50至60米遠，因此不小心地射擊或錯誤操作是非常危險的，會引起眼睛受傷或其它傷害的危險。請確保從頭到尾讀一遍下文中規定的警告事項并遵守其規定，以便于你能玩得愉快。

Operation of this air gun for competition use is restricted to users of 18 years of ages or older, careless shooting and wrong operation may be dangerous and damage eyes or other part.

汽彈槍用于比賽用，僅限于18歲以上使用，錯誤使用可能導致眼部或其他身體部位受傷。

WARNING Always wear goggles
警告 玩槍時，請始終戴着眼保護裝置。



When shooting the air gun for a target or game, you and all participants must wear goggles or other eye protective gear, also paying attention to ricochets. (Pay sufficient attention also to third personnel other than participants.)

當使用氣槍射擊目標或遊戲時，你和所有的參與者都必須戴着防護眼鏡或其它眼保護裝置，同時要注意子彈的彈跳方向。(而且要特別注意不能射向遊戲者以外的第三者。)

WARNING Never shoot at any human or animal.
警告 禁止射擊人或動物

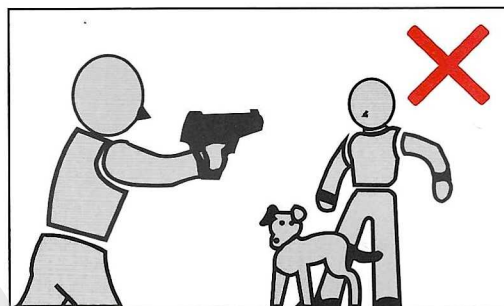

Never aim or shoot a person or animal as the target. Always attach the protective plug to the muzzle, except when you are ready to shoot a target.

不可把人或動物當作目標瞄準或射擊。除非你準備去射擊一個明確的目標。

WARNING You may be punished if you are shooting for a practical joke.
警告 如果用汽彈槍開惡意玩笑，可能會受到懲罰。

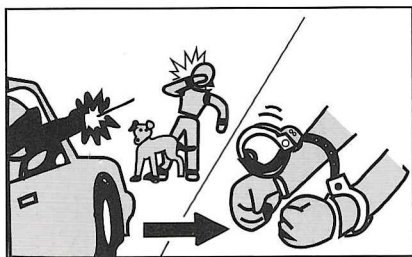

You may be punished if you damage public or personal properties or injure a person or animal even if you are shooting for a practical joke. Always observe manners and enjoy healthy sport shooting.

如果你損害公共的或私人的財產，或者傷害人或動物，即使你是在進行射擊實踐遊戲，你也會受到懲罰。請始終遵守規定，享受有益健康的運動射擊。

WARNING Never look into the gun muzzle.
警告 禁止直接目視槍口

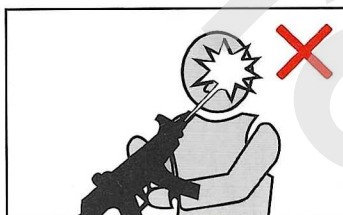

Do not look directly into the muzzle to avoid accidental discharge of BB.

不要直接地看槍口，避免BB彈意外射擊。

- Make sure to operate an air gun after recognizing its features.
- We are not responsible for any accidents, events, injuries or repair costs arising from wrong operation and handling or by modification and disassembly of the gun.
- 請確保在了解其特征之后再使用該氣槍。
- 對於任何由錯誤操作或改裝和拆卸氣槍所引起的意外事故，突發事件，受傷或修理費用，我們將不負有責任。

Always read through this manual before operation.

在操作之前必需讀熟這些說明書

WARNING Always direct the muzzle towards a safe direction. 請始終將槍口對準安全的方向。
警告

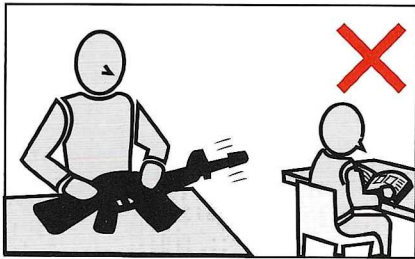

Never direct the muzzle towards a person, animal or other dangerous directions, except when you are ready to shoot a target.

決不能將槍口對準人、動物或其它危險的方向。除非你已準備好要射擊目標。

WARNING Always put the gun in a case or bag when you are carrying it.
警告

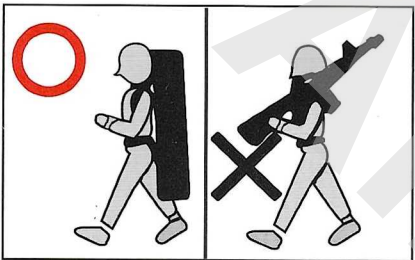

當攜帶該氣槍時，請把它放在盒子或包里。When you carry the air gun, set the selector lever to the safety position and put it in a case or bag.

當你要攜帶該氣槍時，要把選擇杆設定在安全位置，然後再把它放在盒子或包里。

WARNING BB bullets may be shot out even if the magazine is removed.
警告 即使取下彈匣也可能會射出BB彈。

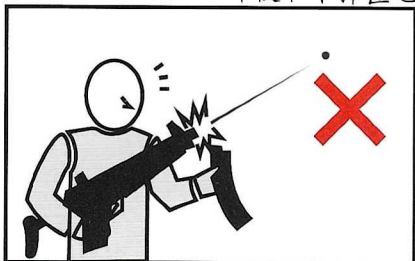

There are cases that bullets remain in the gun after the magazine is disconnected. Pulling the trigger carelessly is extremely dangerous. After removal of the magazine, direct the muzzle towards a safe

direction and pull the trigger to confirm that no bullets remain in the gun.

當彈匣取下來之後，有可能會出現有些子彈還留在槍里的情况。不注意地射擊是極其危險的。在取出彈匣后，將槍口對準安全的方向，扣動扳機以確定槍里沒有殘留子彈。

WARNING Release put away your fingers from the trigger, except when you are ready to shoot a target.
警告

除了你準備好射擊目標外，請不要把你的手指放在扳機上。

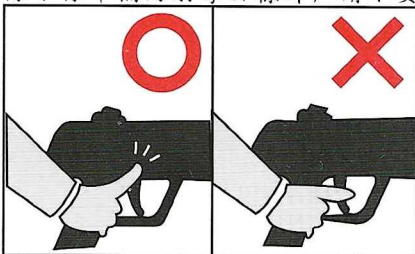

Never put your fingers onto the trigger except when you are shooting a target. Maintaining your fingers on the trigger may cause sudden discharge for some reasons, which is dangerous.

除非你要射擊目標，要不然決不能把手指放在扳機上。一直把手指放在扳機有可能會由于某些原因而突然射擊，這很危險。

WARNING Never shoot the air gun at places where people and cars pass cross.
警告

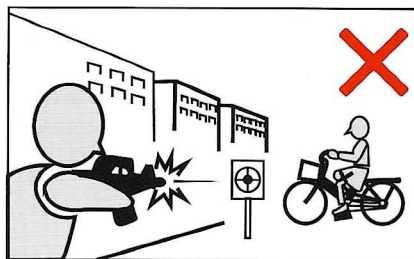

決不能在有人或車子經過的地方射擊氣槍

Select a safe place for operating the air gun, avoiding places where people and cars pass cross.

選擇一個安全的地方射擊氣槍，避免在有人或車子經過的地方射擊。

WARNING Store the air gun at places out of reach by children. 把氣槍存放在兒童够不到的地方。
警告

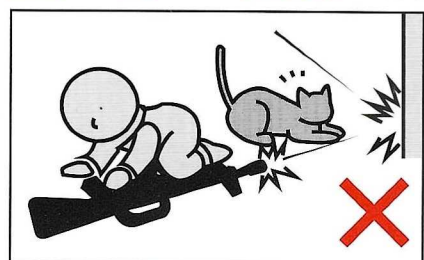

Remove the battery and store the air gun in a case or bag and at a place out of reach by children so that they will not be injured during mischievous play.

不使用時將選擇杆放在安全位置，取出電池，再把氣槍放在盒子或包里，然後把它存放在兒童够不到的地方，以免孩子們因為淘氣地玩耍氣槍而受傷。

WARNING Always set the selector lever to the safety position. 請始終將選擇杆設定在安全位置。
警告

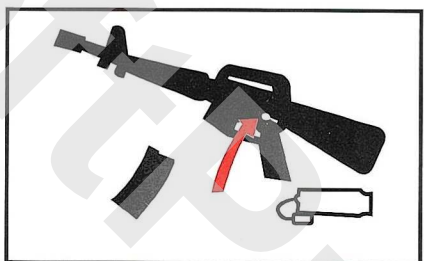

- ① Set the selector lever to the safety position.
- ② Remove the magazine.
- ③ Remove the battery from the air gun.

- ① 將選擇杆設定在安全位置。
- ② 取下彈匣。
- ③ 從氣槍里取出電池。

WARNING Never disassemble or modify the air gun.
警告



This air gun is manufactured under consideration of appropriate performance and operability. Disassembling or modifying the gun may generate danger or adversely affect the performance. So, avoid dissembling or modifying the air gun.

該氣槍是根據適當的性能和操作而制造的。拆除或改裝氣槍可能產生危險或者逆反操作。因此要避免拆除或改裝該氣槍



Read through this manual before shooting paying special attention for safe operation.

在使用前，請詳細閱讀本說明書，以便安全的操作本產品。

● **THOROUGHLY UNDERSTAND THE WARNINGS AND CAUTIONS FOR SAFE OPERATION.**

詳細閱讀說明書中要注意的操作，才能安全的使用本產品。

WARNING
警告

CAUTION
注意

Always observe warnings and cautions strictly. Failing to do so may cause injury, accidents, or damage to the gun.

要嚴格遵守本產品中的警告及注意事項。否則將造成傷害或是槍支的損害。

1 Charging the Battery (Battery and charger sold separately.)

電池充電器(電池和充電器有單獨出售)

- Use the specified battery for the gun. 8.4V.1200mAh Hyper Command Mini Battery Hyper Command Mini Battery.
- Avoid use of non-standard or other brand name batteries. Otherwise, the originally designed functions will not be obtained.

使用槍支專用的電池。8.4伏，1200毫安小電池。Hyper Command 請避免使用非標準或其他品牌的電池，否則將達不到設計要求。

CAUTION The SD and Mini Battery can not be used.
注意 不能使用SD和小類型的電池。

- Use the specified battery charger which is applicable to the above battery. The charger Exclusive Type ac Speed Charger. 使用上述電池專用充電器。
- The battery's capacity power is increased with use of the Ni-cd(battery) Discharger(Sold separately) 使用Ni-cd電池充電器會增加電池的能量。(有單獨銷售)
- Use the correct battery and charge according to respective instruction manuals. We will not be held responsible for any accidents or damage caused by wrongful operation or usage of non-specified batteries.

請根據使用手冊使用標準的電池和充電器。如果沒有按照說明書操作或者使用非專用的電池而引起的事務或傷害，我們將不負任何責任。



- Discharge the battery completely before charging it for the first time and the charging time is 12 hours.
- Battery charging time is about 8 hours, do not extra to avoid the over-charge.
- The temperature can't over 45° during charging or will damage to the battery.
- 在第一次充電前，先將電池余電放淨，充電時間為12小時。
- 電池充電需要8小時左右。不要超過這個時間，以免過度充電。
- 在充電過程中請注意電池溫度不得超過45度，否則將損壞電池。

2 THE NAME OF THE PARTS (For details, see the following pages.)

各部件名稱(具體請參照下面)

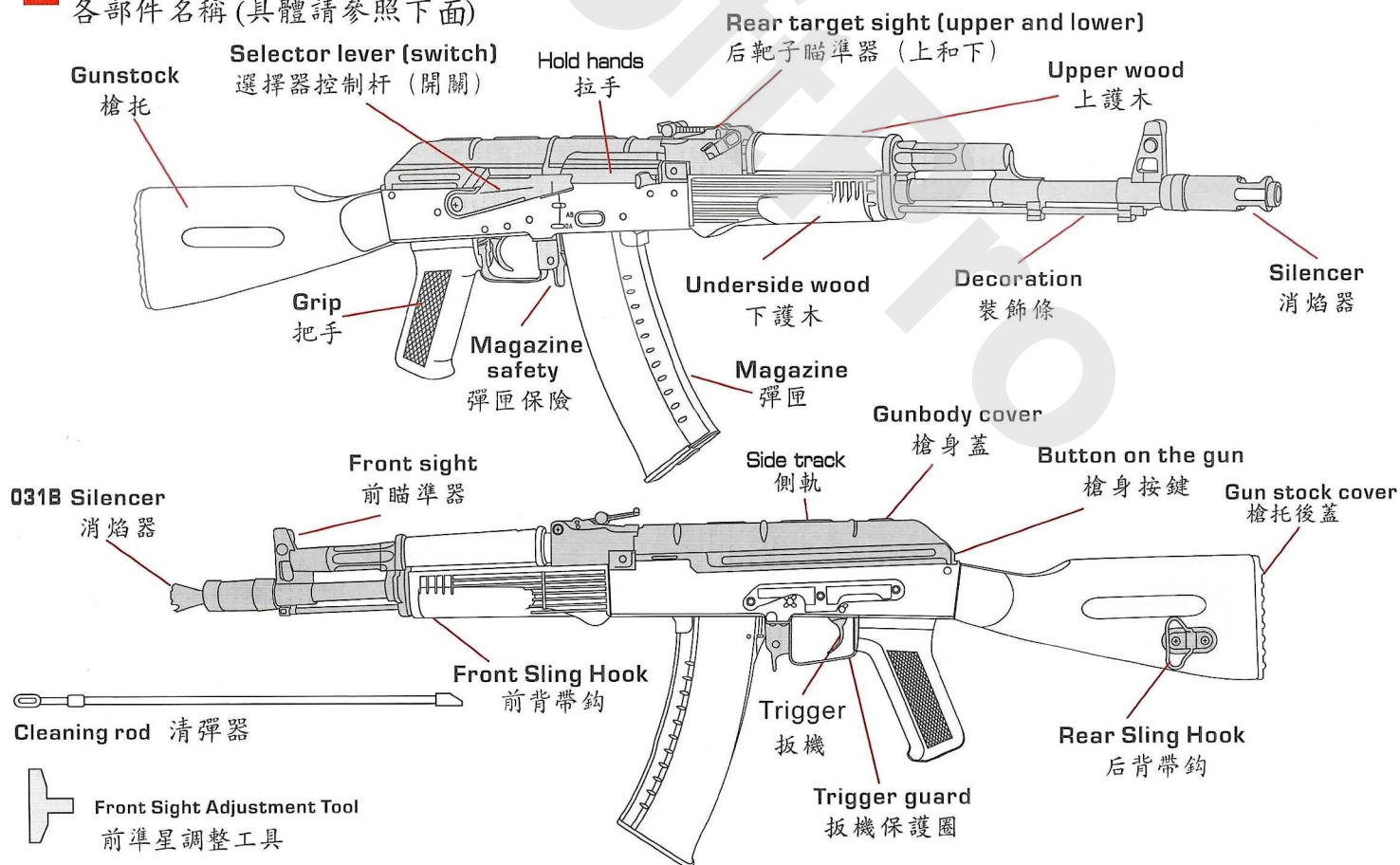

3 Selector lever and safety setting
選擇控制杆和安全裝置

CAUTION Set the selector lever correctly in position; otherwise, malfunction may occur.
注意 將選擇控制杆設置在正確的位置，否則將會發生故障。



1 Safety setting (the trigger cannot be pulled.)
安全裝置 (不能按下扳機)
When you are not firing the gun or during storage always set the selector to the safe position.
當你不在射擊或在裝子彈時，請將選擇器設置在安全位置。

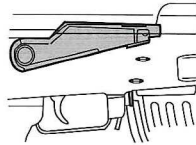

2 Fully automatic (automatic firing)
全自動 (連擊)
The gun will fire automatically while the trigger remains pulled.
按緊扳機，氣槍將自動射擊。

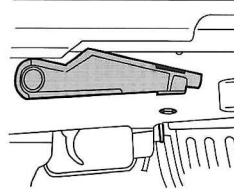

3 Semi automatic
半自動
The gun will fire one shot each time the trigger is pulled.
每按一次扳機，氣槍將發射一發子彈。

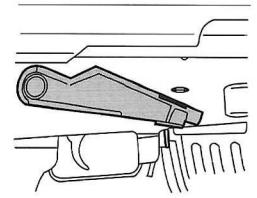

4 Setting the Battery (Set the battery after charging)
安裝電池(用充電器先把電池充滿)

Battery
電池

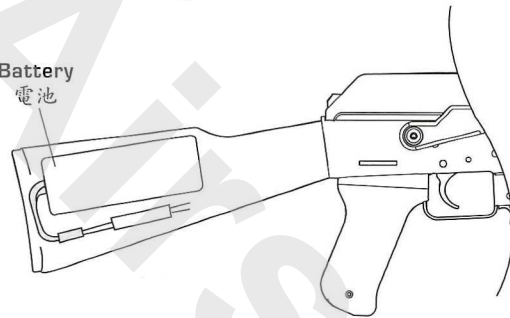

Battery connection
電池連接器

1 Remove the butt plate by pressing it downwards and pull out the connector.

按下蓋板以將其取下并拔出連接器。

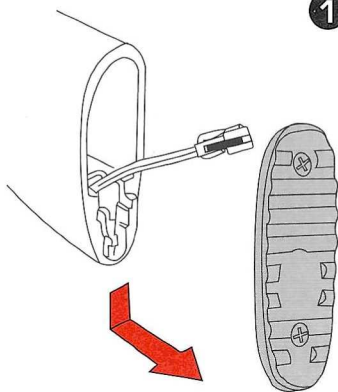

2 Insert the battery in the tail gunstock and connect the jack.

將電池裝入槍托里并接上連接器。

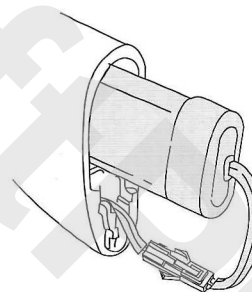

3 Press down the fuse box and insert connectors and cords between the fuse box and battery. Bend cords in the S shape

壓入保險絲盒，然后在保險絲盒和電池之間插入連接器和電綫。將電綫彎曲成S形。

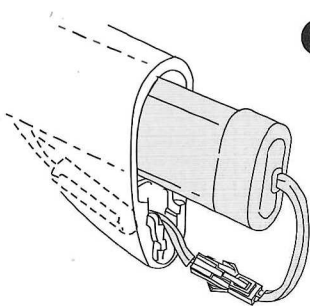

4 When the battery and cords are set in positions, reinstall the butt plate as shown.

當電池和電綫正確安裝后，如圖所示重新裝上蓋板。

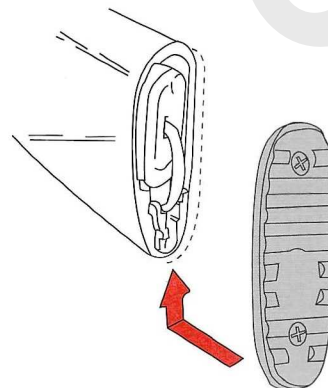

5 SETTING THE MAGAZINE

安裝彈匣

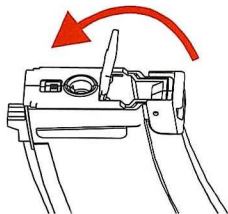

Open the cover of the magazine
打開彈匣蓋。

- 4 Move the gear with hand clockwise until it is fully wound, and the bullets will be sent up automatically. (It can send about 150 rounds automatically)

以順時針方向拔動牙輪，直到上滿鏈，子彈就會自動往上送。(能自動送彈約150發)



CAUTION
注意

The magazine is capable of containing 500 rounds.
彈匣可裝500發BB彈。

2

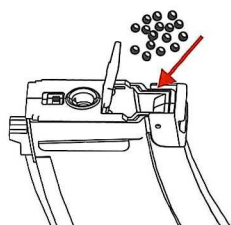

Insert 6mm BB bullets into the loader.
(500 bullets can be loaded)

將6mm BB子彈裝入彈匣。
(可裝入500發BB)

3

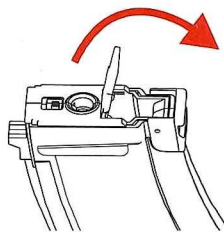

Replace the magazine cover.
蓋上彈匣蓋。

- 5 Set the magazine upward. Install the magazine as illustration.

從上方安裝彈匣。
可以按箭頭所示步驟安裝彈匣。

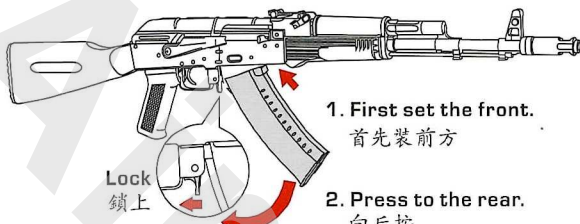

Lock
鎖上

1. First set the front.
首先裝前方

2. Press to the rear.
向后按

3. Press the release lever towards the trigger to lock.
朝扳機方向按下并鎖定。

Magazine stopper relief rib.
彈匣自動裝置解除鈕。



Slide the rib in the arrow direction to remove remaining BB bullets. (Be careful since BB bullets may jump out.)

按箭頭方向移動按鈕取出剩餘BB子彈。(小心BB彈可能會跳出)

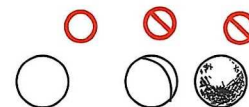

6 REAR SIGHT ADJUSTMENTS

后瞄準器的調節

Rear sight
后瞄準器

Sight
瞄準器

Long distance
遠距離

Short distance
近距離

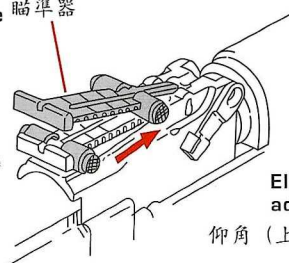

Press
壓

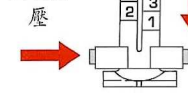

Elevation (up/down)
adjustment button

仰角(上/下)調節按鈕

The 031 series rear sight is a tangent type which is adjusted vertically according to distance to the target.

031系列氣槍的后視屬於相對獨立的類型。它是根據目標的距離垂直方向調整的。

Press the adjust button and slide it forward or backward to move the sight up or down. The larger the number, the longer the distance to the target.

按下調整按鈕向前或向后滑動以調整視野，數字越大，距離目標就越遠。

- Insert the front sight adjustment tool in the front sight and turn it for adjustment.
將前準星調整工具插進前準星里，然後轉動以作調整。

Counterclockwise:
lower sight point
逆時針方向：
降低瞄準點

Clockwise:
higher sight point
順時針方向：
提高瞄準點

CAUTION
注意

Be careful so as not to loose the adjustment tool.
注意不要鬆開調整工具。

The cocking lever can be moved.
拉手是可移動的

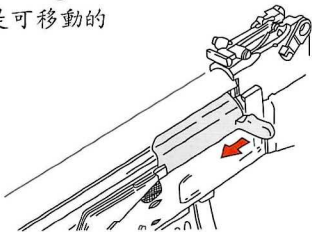

Variable hop-up adjustment lever

可變化的跳動調整杠

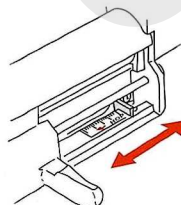

INSTALLATION OF THE ELIMINATE BLAZE IMPLEMEN

清焰器的安裝

- 1 While pressing the lock button.
按下鎖定鍵

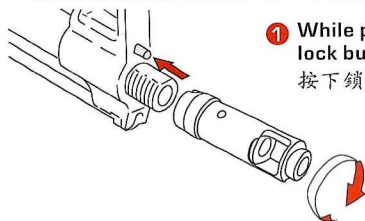

The eliminate blaze implement is fixed by counterclockwise as in the case of real gun.

與真槍一樣，清焰器是用反向綫固定的。

- 2 Remove by turning the Eliminate blaze implement.
旋轉清焰器

CAUTION
注意

- There are possible cases that no firing occurs after pulling the trigger in the semi-atuo mode. In this case, do not pull the trigger furiously. Fire 5 to 6 shots in the full auto mode and then return to the semi auto operation. 在半自動的狀態下，有可能你按住扳機之後，子彈沒有射出來。遇到這種情況，不要猛烈地按住扳機，在全自動的狀態下，射擊5到6發，然後再調到半自動的狀態下嘗試。
- Smell may be generated from motor for a while when a new air gun is operated. this is the normal operation of the gun. 剛開始使用新氣槍時候，可能會有一股味道，這股味道是電機運轉時產生的，這種情況屬於正常現象。
- The hopping up operation may be unstable for 200 to 300 rounds after using silicone oil, this is the normal operation of the gun. 使用潤滑油之後，槍支的前200到300發可能不太穩定，這種情況屬於正常現象。

剛開始使用新氣槍時候，可能會有一股味道，這股味道是電機運轉時產生的，這種情況屬於正常現象。

- The hopping up operation may be unstable for 200 to 300 rounds after using silicone oil, this is the normal operation of the gun. 使用潤滑油之後，槍支的前200到300發可能不太穩定，這種情況屬於正常現象。

8 Firing (Confirm your shooting area is safe before beginning firing.)

射擊(射擊前，確保射擊地方是安全的)

CAUTIONS ON MOTOR AND BATTERY
發動機和電池使用注意事項

- Charge the battery if the firing cycle becomes slow. 當射擊速度變慢，請充電。
- Give the air gun a rest for 5 to 10 minutes after firing about 500 rounds, in order to ensure long service lives of the motor and battery. 為了確保發動機和電池的壽命，在射擊500輪后，給氣槍5-10分鐘的間歇。

WHEN BULLETS ARE CLOGGED 當子彈阻塞時，應採取的措施

- If bullets are clogged, remove them and apply a few drops of silicone oil in to the chamber from the magazine entrances shown or spray silicone oil for 0.5 or 1 sec, to obtain smooth continuous. 假如子彈阻塞，把子彈取出來，為了以後順利的射擊，請從子彈匣的入口處往槍膛滴上或噴上幾滴潤滑油。

AFTER OPERATION 使用之後

- Remove the magazine and dry fire the gun in the semi auto mode directing the muzzle to a safe direction. (Otherwise the spring may be weakened). Set the selector to the Safe position. 把子彈匣取出，在半自動的模式下，把槍對着安全的地方射擊。(否則，彈簧彈性可能會變弱)，把選擇器調到安全(safe)這一檔。
- Bullets may remain in the chamber even if the magazine contains no bullets (or if the magazine is not connected) (Two or three bullets may drop from the magazine, this is the normal opwear of the gun.) 即使彈倉里沒有子彈，(或彈倉被取出后)子彈也可能會留在槍膛里。
- Always disconnect the battery and attach the protective cap whenever you do not operate the air gun. 當你不用氣槍時，必須斷開電池。

Always attach the protective cap during storage.

- 1 Set the selector lever to Semi or Full Auto. 把控制杆從半自動位置設置為自動
- 2 Pull the trigger. 按住扳機

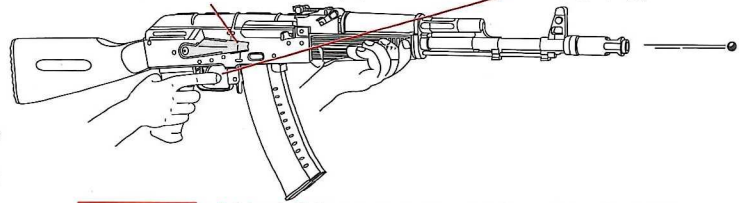

CAUTION
注意

A blank firing may occur after triggering after the magazine, this is the normal operation of the gun. 當在你裝上子彈開始射擊時，可能有空白射擊，這是屬於槍的正常的情況。

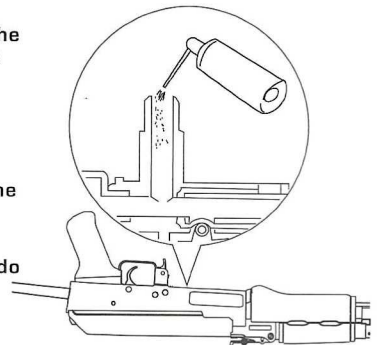

9 TROUBLE CLINIC(TROUBLE SHOOTING)

故障診斷(維修之前請確認是否發生故障)

Use of poor quality BB bullets will cause problems. Never disassemble or modify the gun.

如使用低質量的BB彈將出現問題。不要拆卸或修改槍支。

SYMPTOM 症狀	CAUSE 原因	ACTION 方法	SYMPTOM 症狀	CAUSE 原因	ACTION 方法
No operation at all 無法操作	Select or is set to safety. 選速(器)杆調在安全這一檔(Safety)	Set the selector lever to Semi or Full Auto. 把選速(器)杆調在半自動或全自動檔	Impossible semi-auto operation. (Single out) 不能半自動操作	Insufficient battery power. 電池電量不足	Charge the battery. 給電池充電
	Battery is not charged. 電池沒有充電	Charger the battery. 給電池充電	Automatic firing become shorter. 連發射擊變慢	Insufficient battery power. 電池電量不足	Charge the battery. 給電池充電
	Battery connector is disconnected. 電池連接器被斷開	Connect the connector. 連接連接器	Shooting distance become shorter. 子彈射程變短	Worn or damaged chamber packing. (槍)膛材料太舊或壞了	Consult your dealer or us for overhaul maintenance or repair. Replace the chamber packing, piston packing (O-ring) and piston assembly. 向經銷商諮詢如何維修重新換上槍膛材料，活塞材料(O形圈)和活塞組裝件。
	The ⊕ and ⊖ or battery connector is revers. 電池的正負極連接器倒置	Connect the connector correctly. (check the fuse) 正確連接連接器(檢查保險絲)			
Fuse is blown out. 保險絲爆裂	Relace the fuse. (See page 8) 重新換上保險絲(見8頁)	Faulty BB bullets. (Too small or heavy) Bb子彈不合格(大小或太重)	Use the genuine BB bullet 使用質量合格的BB彈		
Although motor is removing, bullets jump out. 電機沒有發生故障，但子彈無法正常發射。	Bullets are clogged in the magazine. 子彈阻塞在彈倉里	Insert the charging rod into the magazine and move up and down a few times to remove clogged bullets. 用裝載杆插進彈倉里，上下移動幾次，把阻塞的子彈移出。	Too loud operating noise. 噪音太大	Gear problem caused by too many blank firing or worn or damaged gear. 太多的空白射擊導致齒輪出現問題或者齒輪老化或損壞。	Consult your dealer or us for overhaul maintenance ,part replacement (gear, etc) or repair. 向經銷商諮詢如何維修，零件替換(齒輪等)
	Blets are clogged in the chamber. 子彈阻塞在(槍)膛里	Remove clogged bullets using the cleaning rob. 用(槍)枝的清彈器把阻塞的子彈取出			
	Faulty gear. 齒輪壞了	Purchase the replacement gear from your dealer and repair. 向經銷商購買新的齒輪后進行維修	Worn or damaged chamber packing. (槍)膛材料太舊或壞了	Turn the hop adjustment lever toward HOP. 把調節杆調到HOP位置	
Impossible full-auto operation. (Automatic firing) 不能連發(子彈無法射出)	Insufficient battery power. 電池電量不足	Charge the battery. 給電池充電	Being wet or drop into water.(rain) 槍支弄濕或掉進水里(雨淋)		No hop setting. 沒有設置HOP
	Faulty bullet feed of magazine. 彈倉里的子彈裝錯	Repair clogging the magazine. 清理彈倉里的堵塞物		Faulty BB bullets. (Too small) BB子彈不合格(太小)	Stop operation immediately, disconnect the battery ,wipe off water from inside the main body and the battery , and after complete dry, carry out trial firing, if no operation or malfunction is detected, consult your dealer or us for repair. 立刻停止使用，斷開電池，把電池和槍支內部的主要部分擦干，等槍支完全干了之後，再嘗試射擊。假如無法使用或者發現故障。向經銷商或我們諮詢如何維修。
Impossible semi-auto operation. (Single shot) 不能單發	Poor electrical connection. 電線連接不好	Consult your dealer or us for overhaul maintenance or repair. 向經銷商諮詢如何維修			
	Deviation in gear timing. 齒輪調配偏離	Set to semi auto firing 5 to 6 rounds in full auto. 在全自動這一檔開火5到6次后調到半自動檔			

CAUTION
注意

- If the hop-up is adjusted excessively causing clogging of bullets, immediately stop operating the gun, return the lever to Normal, fire 2 or 3 shots and readjust.

假如hop-up過分地調整可能會導致子彈的阻塞，遇到這種情況，立刻停止使用，把調節杆調至正常射擊(Normal)狀態下，射擊2到3發，然後重新調整。

- Since a precision tight barrel is used, use of dirty bullets or those with burrs causes clogging of bullets and possible fatal damage to the mechanical box and system.

由于槍管非常精密，如果使用臟的子彈可能會導致子彈阻塞和很致命的損壞槍支。

WARNING
警告

- Never hold the gun side ways as the BB bullets will curve tight or left. This is due to the HOP-UP system.

不要從側面握住槍支進行射擊，因為BB子彈射出時可能會偏左或者偏右。



10 VARIABLE HOP UP SYSTEM 可變化的Hop Up系統

By producing a back-spin on the BB bullets, this system allows for straighter and longer distance shooting than normal air gun. Unlike the fixed type, the variable hop up system permits one-touch adjustments using the dial and lever, making it an ideal hop up system.

通過使子彈逆轉，可以使射擊比一般的氣槍射得更直和更遠。不像其他的固定類型的氣槍一樣，可變化的Hop Up系統可以使用轉盤和調節杆來進行調整。

▶ Adjustment Procedure[Adjust by carry out trial firing]

調節程序 (通過試射擊來進行調節)

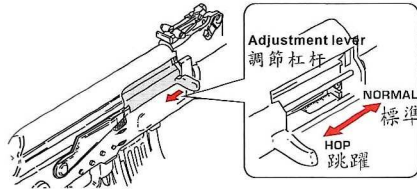

- Gradually turn the adjustment dial towards Hop to give hop up to bullets. (The best setting is where bullets fly horizontally.)

把調整鍵慢慢移向跳躍方向。(最佳設置為子彈水平方向射出)

- Turning excessively adversely affects the trajectory. So stop turning the hop adjustment lever when bullets fly horizontally.

向相反的方向用力的扭轉可能會影響到彈軌。因此，如果子彈能够水平射出，就停止扭轉調節杆。

- The best position is where the bullets fly horizontally, and the longest flying distance is obtained.

最佳的位置是子彈水平方向射出，此位置使子彈達到最遠射程。

Too much hop-up(return the lever towards NORMAL)

過度上旋 (將調節杆拔回正常位置)

Best position
最佳位置



Not enough hop-up(return the lever towards NORMAL)

上旋不到位 (將調節杆拔回正常位置)

OPERATIONAL CAUTION
(strictly observe the following caution)

操作注意事項: (要注意以下的事項)

- Moving the lever too much towards HOP causes bullets to clog. Firing the gun with clogged bullets damages the piston and gears.
調整杆過度調向跳躍方向會導致子彈堵塞，子彈堵塞的情況下射擊會導致活塞和齒輪的損壞。
- If bullet clogging occurs, immediately stop firing the gun, return the hop lever to the Normal position and remove clogged bullets using the cleaning rod.
如果子彈堵塞，請立即停止，把跳躍杆調至正常位置，用清彈器取出堵塞子彈。
- Make sure to return the hop adjustment lever to the Normal position when removing clogged bullets or cleaning. (Otherwise, the chamber packing is damaged.)
在取出阻塞子彈時或進行清潔時，要把hop調節杆調到正常的位置 (Normal) (否則可能會損害槍膛)
- Never use used or dirty bullets. (Otherwise, the chamber becomes dirty, resulting in unstable hopping up.)
不要重複使用子彈或使用臟子彈。(否則彈腔會變臟，從而導致跳躍的不穩定)
- When about 10000 rounds are fired, spray silicone oil into the chamber for 0.5 to 1 dec. (See 11 on page 8. The hopping up operation may be unstable for 200 to 300 rounds after spraying the silicone oil, this is the normal operation of the gun.)
射擊大約10000粒子彈，用硅油噴彈腔0.5-1秒。(在噴硅油后，200-300輪射擊的跳躍操作會不穩定，這種情況屬於正常現象)
- We will not be held responsible for any damage or accidents arising from wrongful operation, disassembly and modification of the gun. Any costs for repair of such damage shall be paid by the user.
由于錯誤操作、重組裝或改裝氣槍所引起的損壞或意外，我們一律不予負責，由此產生的維修費用由用戶自行承擔。

● Construction Diagram 結構圖

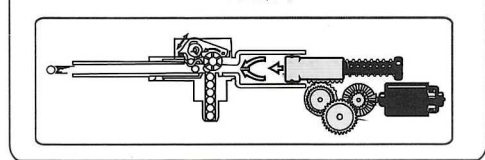

WHEN HOPPING UP IS IMPROPER 跳躍不正常現象

SYMPTOM 症狀	CAUSE 原因	ACTION 方法
Bullets flying upwards. 子彈向上飛	Too much hop setting. (hop) 設置太大	Gradually return adjustment lever towards Normal. 把調節杆逐漸地調到正常狀態。
Short flying distance of bullets (less hopping up effect). 子彈射程太短 (短于跳躍應有效果)	Too much hop setting. (hop) 設置太大	Gradually return adjustment lever towards Normal. 把調節杆逐漸地調到正常狀態。
	Hop packing contaminated by oil or dirt. Hop包裝被油迹或污垢沾污	Fire bullets equivalent to 4 or 5 magazines or clean the chamber using cleaning rod. 用(槍枝的)清彈器清潔槍膛
	Worn or damaged hop packing. Hop包裝太舊或被損壞	Purchase the replacement part at your dealer or from Marui and replace it. 向經銷商或我們購買所需配件，更換hop裝置

SYMPTOM 症狀	CAUSE 原因	ACTION 方法
Cannot adjust 不能調節	Damaged adjustment lever or other parts. 調節杆或其他部件損壞	Purchase the replacement part at your dealer and replace it. 向經銷商購買所需配件，更換hop裝置
Frequent bullets clogging 子彈經常阻塞	Too much hop setting. (hop) 設置太大	Gradually return adjustment lever towards Normal. 把調節杆逐漸地調到正常狀態。
	Improper or too large sized BB bullets. BB彈不合適或太大了	Use the BB Bullets for Electric Gun. 使用標準BB彈
	Dirty hop packing. Hop包裝弄臟	Clean using the cleaning rod or consult your dealer for repair. 用(槍枝的)清彈器清潔或者向經銷商諮詢維修。

11 MAINTENANCE 保養

1. Fuse Replacement Procedure. 更換保險絲

The fuse box comes out when the connectors are pulled out of the stock.
當連接器從槍托里被拉出來時，也把保險絲盒拉出來。

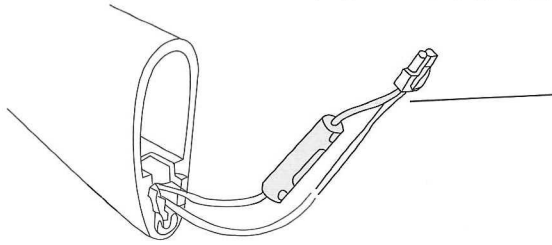

Fuse box [when fuse is replaced, push into the stock all the way.

保險絲盒[當更換好保險絲后，直接把它推進槍托里。]

Glass tube fuse 保險管
You can buy it at a near-by electric shop or gas station.
你可以在附近的五金店或電器店買到它。
15A Fuse common for electric gun series.
常用於電動槍系列的15A保險絲

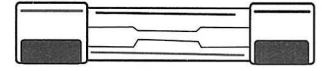

2 Remove the obstruct bullets 拆卸堵塞子彈

① Insert the cleaning rod into the bore.
沿槍管的內邊緣插入清彈器。

CAUTION
注意

The ornamental can not be used for cleaning the obstruct bullets.

附在氣槍上的裝飾條模型不能用於清除堵塞子彈。

CAUTION
注意

Make sure to insert the cleaning rod AFTER returning the hop up lever to the Normal position. (Hop-OFF)

確保跳躍調整杠回復到正常位置才能插入清彈器。

② Be careful so that the angled part of the cleaning rod faces down, and remove clogged bullets.

確保清彈器的角部分向下，並清除堵塞子彈。

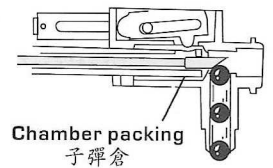
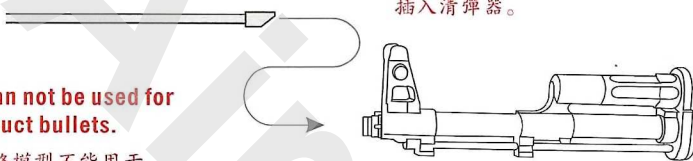

Chamber packing
子彈倉

3. Maintenance When Bullet Speed Become Low 當子彈速度變慢時怎樣維修

Cut the cotton to the size shown. Adjust the length accordingly so that it can be inserted smoothly into the barrel.

將棉綫剪成如圖所示的大小。適當地調整長度，以於將其順利地插進槍管里。

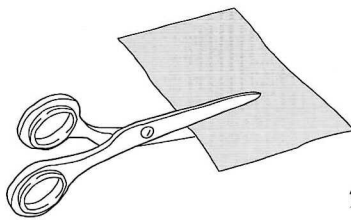

Cotton cloth
綿布

Width:
Approx. 10mm
寬度：大約10mm

Length:
Approx 25~30mm
長度：大約25-30mm

Wind the cut cotton cloth.
轉動把綿布卷起來

Hold at the leading end of the rod and insert the rod into the barrel while turning the rod.

當調節杆關閉時，握住杆杠的末端把它插入槍管里。



CAUTION
注意

Inserting the rod will be difficult if you hold rod at the end.

假如你緊握清彈器的末端，清彈器插進去可能會很困難。

CAUTION
注意

- Always carry out maintenance AFTER returning the hop up lever to the Normal position. (Hop-OFF)
- Since the chamber is a precision component, avoid use of used BB bullets.
- 在將上旋杆撥回正常位置后，才能進行維修保養。
- 由於槍膛是一個精確的部件，請避免使用用過的BB彈。

Hop chamber packing
彈跳槍膛封墊



Bullet entrance
子彈入口

Apply a few drops of silicone or Teflon oil.
滴幾滴硅樹脂或特氟綸油

① Drop a few drops of silicone oil or Teflon oil from the bullet entrance, insert BB bullets into the magazine and fire bullets equivalent to 1 or 2 magazine.

從子彈的入口處滴幾滴潤滑油。把BB子彈裝進彈倉，射擊1或2次。

② To complete the cleaning, use the cleaning rod (with cotton) as shown below, to remove excess oil.

使用槍支清彈器按照以下說明除去多餘的潤滑油。

4. FINE ADJUSTMENT OF GEAR ENGAGEMENT 齒輪啮合的微調

CAUTION
注意

Only when the motor noise becomes high after operations for a long period of time, conduct the fine adjustment as shown.
若使用時間過長，電機發出很大的的噪音時，請按如圖所示對電機進行微調。

Hold the grip during adjustment. Otherwise, the main body will drop since the grip set screw is removed.

在調整時要握緊把手。否則，主體會因為固定把手的螺絲被取下來了而掉出來。

Remove the screw from the grip bottom.
在把手底部擰開螺絲。

M3 hexagon wrench
M3六邊形扳手

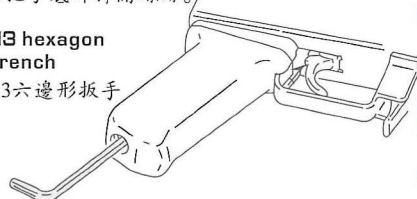

Insert M3 hexagon wrench into the screw hole to adjust.

將M3六邊形扳手插入螺絲孔里調整。

CAUTION
注意

- It is recommended to lock the adjustment screw by a screw locking agent or instantaneous adhesive after adjustment of the motor position is complete.
- Normally, do not attempt to adjust.
- Be careful as not to overly tighten the screw as it will damage the gun.
- 建議你在馬達位置調整完成后，使用螺絲釘固定器或瞬間粘劑固定調整螺絲釘。
- 通常不要隨便調整。
- 注意不要過度擰緊螺絲釘以免損壞氣槍。

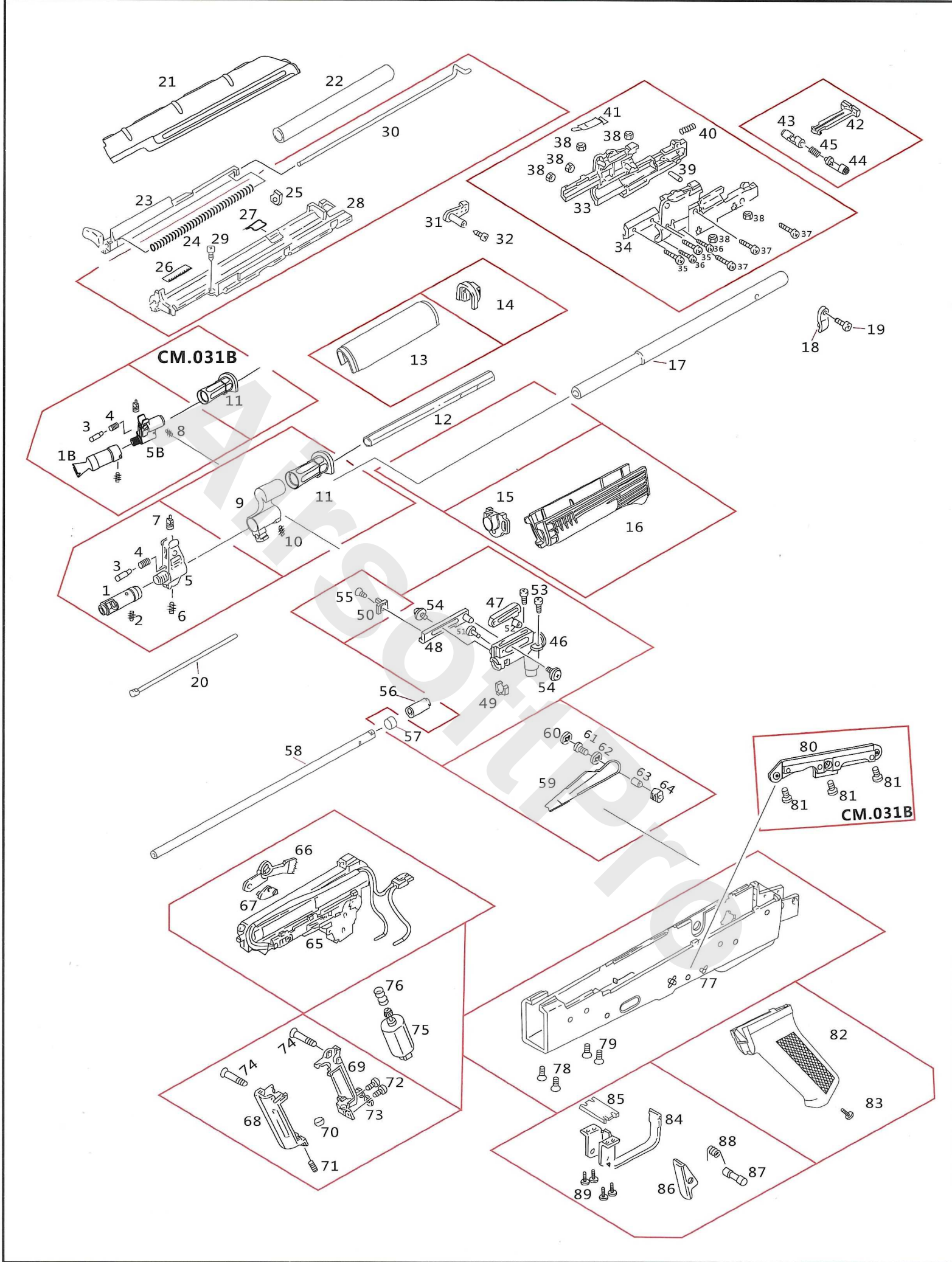

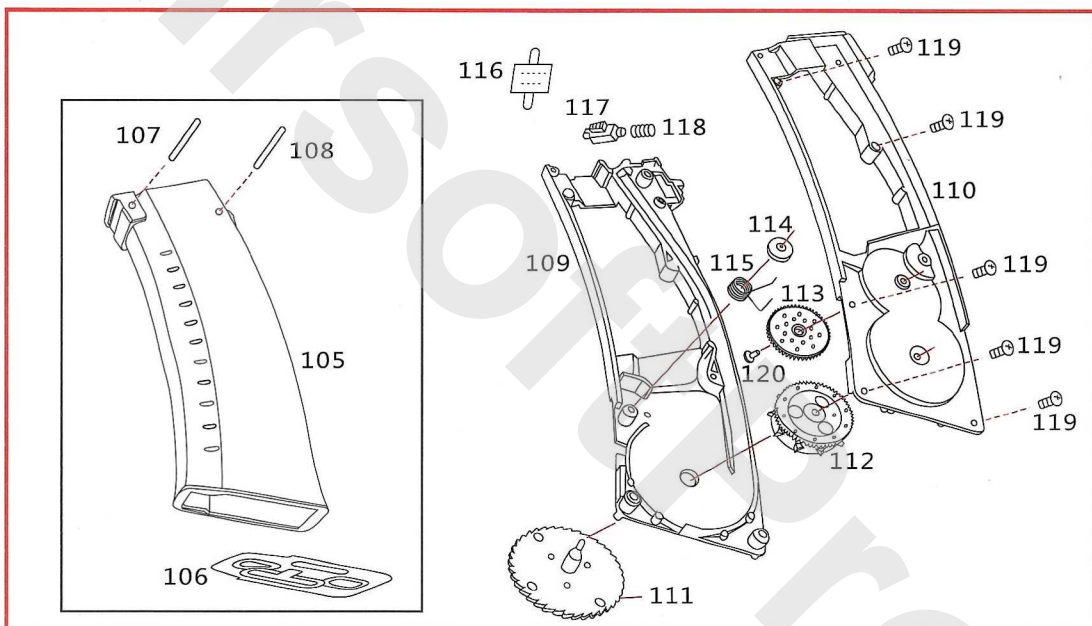
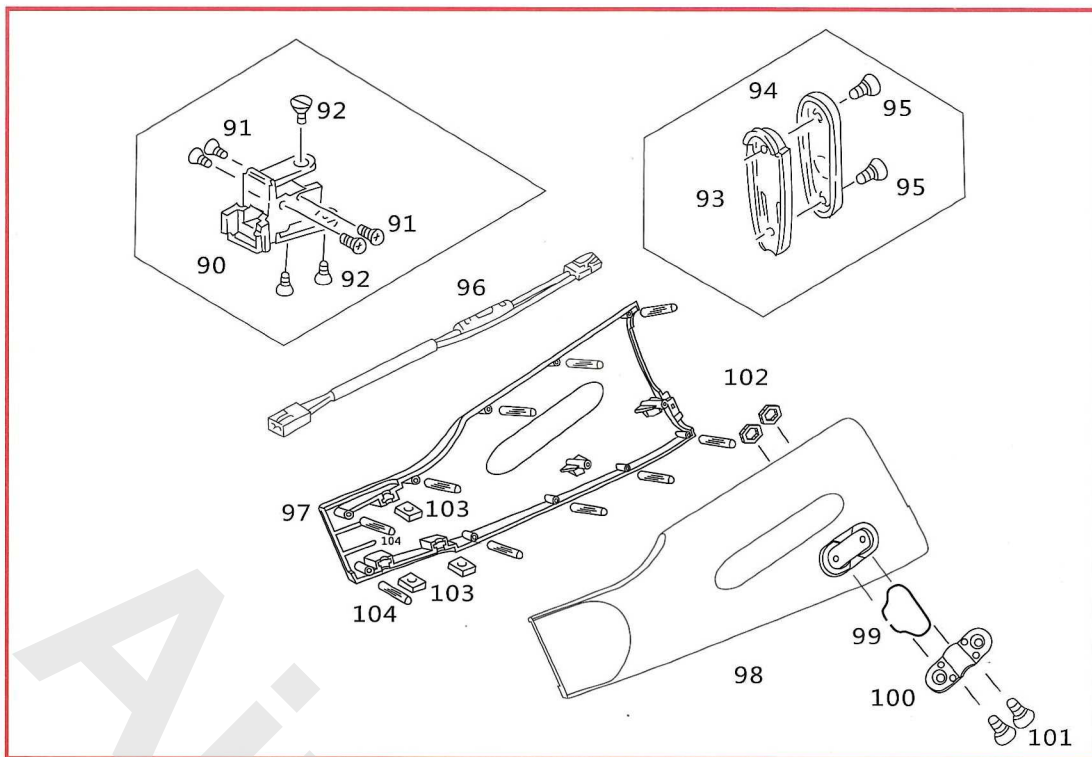

CM.031 (031B)

- | | |
|---|--|
| 1.Flash hider | 消焰器 |
| 1B. cm031b flash hider | 031B 消焰器 |
| 2.Screw (m3*6) | M3*6钻力 |
| 3.Front barrel | 枪头管正铁轴 |
| 4.Spring ($\phi 0.4 * \phi 4.0 * 17.5 * 11T$) | 压簧($\phi 0.4 * \phi 4.0 * 17.5 * 11T$) |
| 5.Front gun tip | 枪头 |
| 5B. 031b gun tip | 031B枪头 |
| 6.M3 *5 HMHO | M3*5 HMHO |
| 7.Front sight | 前准星 |
| 8.Shatft $\phi 2.5 * 16.5$ | 光轴 $\phi 2.5 * 16.5$ |
| 9.Gun barrel | 枪筒 |
| 10.Screw m3*3 | M3*3钻力 |
| 11.Up gun guard cap | 上护木前盖 |
| 12.Hexangular iron slice | 六角铁条 |
| 13.Up gun guard | 上护木 |
| 14.Up gun guard back cap | 上护木后盖 |
| 15.Down gun guard front cap | 下护木前改 |

- | | |
|--|--|
| 16.Down gun guard | 下护木 |
| 17.Out gun barrel | 枪筒管 |
| 18.Outer gun barrel located slice | 枪筒卡只 |
| 19. $\phi 3 * 10$ PAHO | $\phi 3 * 10$ PAHO |
| 20.Decoration | 装饰条 |
| 20B. 031b decoration | 031B装饰条 |
| 21.Gun body cover | 枪身盖 |
| 22.Add weigtght slice | 加重铁条 |
| 23.Cocking lever | 拉手 |
| 24.Spring $\phi 0.45 * \phi 4.5 * 139 * 54T$ | 拉手圆位簧 $\phi 0.45 * \phi 4.5 * 139 * 54T$ |
| 25.Spring located slice | 上膛栏杆弹簧限位块 |
| 26.Hop up | Hop up调节刻度标 |
| 27.Located slice | 枪身按键铁条限位只 |
| 28.Battery case | 电池座 |
| 29. $\phi 2.0 * 6.5$ PAHO | $\phi 2.0 * 6.5$ PAHO |
| 30.Gun body cover release | 枪身按键铁条 |

31.Up gun guard located nail	上护木限位钉	76.Motor spring	电机压簧
32.M3* 5 kmho	M3*5 KMHO	77.Gun body	主体
33.Right gun sight	右准星座	78.M3 * 14 KMHO	M3*14 KMHO
34.Left gun sight	左准星座	79.M3 * 12 KMHO	M3*12 KMHO
35.M3* 20 PMHO	M3*20 PMHO	80.Side rail	侧轨
36.φ3 *10 PAHO	φ3*10 PAHO	81.φ30*7.5 TBHO inner hexagon 2mm	φ3.0*7.5 TBHO内六角2mm
37.φ3 * 16 PBTHO	φ3*16 PBTHO	82.Gun grip	手把
38.M3 nut	M3螺母	83.M4 *5 TMHO	M4*5 TMHO
39.φ2 *12 shaft	φ2*12光轴	84.Rigger loop	扳机圈
40.Spring(φ0.5 * φ3.35 *20* 20t)	压簧(φ0.5*φ3.35*20*20T)	85.Rigger loop stator	扳机圈固定铁片
41.Staff guage panel	标尺铁片	86.Magazine safty	弹盒保险
42.Staff guage	标尺	87.Magazine release shaft	弹盒扣位保险铁轴
43.Staff guage release spring	标尺按键弹簧座	88.Magazine release spring	弹盒扣扭簧
44.Staff guage release	标尺按键	89.φ3 *10 PBTHO	φ3*10 PBTHO
45.Rear sight release spring (φ0.4*φ3.9*8*7t)	后准星按键簧 (φ0.4*φ3.9*8*7T)	90.Gun body connector	枪身连接体
46.HOP-UP	过只	91.M3 * 6 KMHO	M3*6 KMHO
47.Rubber selector	橡胶调节片	92.M4 * 10 KMHO	M4*10 KMHO
48.Selector	过只调节片	93.Gun stock coverrelease	枪托后盖扣片
49.Gun barrel connect link	枪管接只	94.Gun stock cover	枪托后盖
50.Block	扣手块	95.M4 * 8 KMHO	M4*8 KMHO
51.Nail	管正钉	96.Wire	电源线
52.Hop-up selecor ruber	调节圆柱橡胶	97.Right gun stock	右枪托
53.φ2.3 * 8 PWAHO d=φ5.0	φ2.3*8 PWAHO D=φ5.0	98.Left gun stock	左枪托
54.φ2.0 * 4 PWBHO d=φ5.0	φ2.0*4 PWBHO D=φ5.0	99.Rear gallus hook	后背带环
55.φ2.0 *4 KBHO	φ2.0*4 KBHO	100.Rear gallus hook cover	后背带环盖
56.Hop-up rubber	过只橡胶	101.M3 * 8 KMHO	M3*8 KMHO
57.Inner barrel sleeve	枪管铜套	102.M3 nut	M3螺母
58.Inner barrel	枪铜管	103.M4 nut	方形螺母M4
59.Fire selector	发弹调节片	104.Shaft	滚花铁轴
60.Outer fire selecor	发弹调节器外扣只	105.Magazine cover	弹盒外壳
61.M4 * 10 TMHO	M4*10 TMHO	106.Magazine rear cover	弹盒后盖
62.Fire selector ring	发弹调节器卡环	107.φ2 *21.5 shaft	φ2*21.5花轴
63.Fire selector cobby barrel	发弹调节器铜管	108.φ2 *25.5 shaft	φ2*25.5花轴
64.Located slice	定位卡只	109.Right trajectory	右弹道
65.Main gear box	02波箱主体	110.Left trajectory	左弹道
66.Gear	传动牙条	111.Gear	上链牙轮
67.Rigger block	扳机堵块	112.Clockwork spring base + clockwork spring + clockwork spring cover gear	发条座+发条+发条盖牙轮
68.Motor right cap	电机罩右	113.Driver	传动牙轮
69.Motor left cap	电机罩左	114.Gear	送只轮
70.Motor shim	电机垫片	115.Gear spring	送只轮扭簧
71.M4 *4 screw	M4*4钻力	116.Magaziine cover	弹盒盖
72.M3 * 8 PMHO	M3*8 PMHO	117.Bullet block	卡弹片
73.Spring shim φ5.2 * φ3.1 *1.0	弹簧垫片φ5.2*φ3.1*1.0	118.Spring(φ0.4 * φ3.9 *7.5)	弹簧(φ0.4*φ3.9*7.5)
74.M3 * 21 KMHO	M3*21 KMHO	119.φ2.6 * 10 PAHO	φ2.6*10 PAHO
75.Motor	电机	120.Ballistic transition nail	弹道过渡钉

ELECTRIC AIR GUN 電動汽彈槍			
Name	名稱	CM-031	CM-031B
Overall length	全長	950mm	850mm
Weight	重量	2800g including battery 2800克 包含電池	3295g including battery 3295克 包含電池
Magazine capacity	裝彈數	500 rounds 500 发	500 rounds 500 发
Bullet	子彈	6mmBB bullets 6mmBB 弹	6mmBB bullets 6mmBB 弹
Initial bullet speed	初速度	102m/sec (0.2g bullet) 102 米/秒 (0.2g 子彈)	102m/sec (0.2g bullet) 102 米/秒 (0.2g 子彈)
Full auto shooting speed	連射速度	750 to 850 rounds/min 750~850发/分	750 to 850 rounds/min 750~850发/分